

morsø



By appointment to The Royal Danish Court

morsø

Installation and Operating Instructions

Morsø 5660

For use in North America



Congratulations on the purchase of your new Morsø stove!

Morsø, which is the largest supplier for the Danish market, has manufactured stoves of the highest quality since 1853. By following the instructions overleaf, we are sure that you will enjoy the use and the benefits of your stove for many years to come.

Contents

1.0	Installation of your Morsø stove	Page no.
1.1	The chimney / flue system	9
1.2	Flue connection	10
1.3	Connecting to existing chimney	10
1.4	Positioning the stove	13
1.5	Installing the blower (optional)	15
2.0	Operation	16
2.1	Before you start firing	16
2.2	Lighting & loading intervals	17
3.0	Maintenance	20
3.1	Exterior maintenance	20
3.2	Internal maintenance	20
3.3	Cleaning the stove & the flue	22
3.4	Leaving the stove for extended periods	23
3.5	Parts diagram	24
3.6	Parts list	25

Read this entire manual before you install and use your new room heater. If this room heater is not properly installed, a house fire may result. To reduce the risk of fire, follow the installation instructions. Failure to follow instructions may result in property damage, bodily injury, or even death.

Contact local building officials about restrictions and installation inspection requirements in your area.

Save these instructions

Tested &
Listed By



Portland
Oregon USA

OMNI-Test Laboratories, Inc.

Report No.: 192-S-14d-2

Optional Accessories

A wide range of accessories (such as handling gloves, fireside tools, glass cleaner and heat-proof paint) are available for use with your Morsø stove. They help with day-to-day running and maintenance. Contact your Morsø dealer for more information.

The Morsø 5660 Insert meets the U.S. Environmental Protection Agency's emission limits for wood heaters sold on or after July 1, 1990

The Morsø 5660 Insert have been tested by OMNI-Test Laboratories, Inc. The test standards are UL1482-2011 for the United States and ULC S628 – M93 for Canada.

The stove is listed for burning wood only. Do not burn other fuels.



Cast iron

Cast iron is a live material. There are no two ovens that are identical. This is partly due to the tolerances of the casting process, partly because the ovens are a work of craftsmanship. Minor unevennesses may also occur in the cast iron surface.

1.0 Installation of your Morsø stove

Installation of woodburning stoves must be safe and legal.

If your Morsø stove is not installed correctly, it may cause a house fire. To reduce the risk of fire, the installation instructions must be followed carefully. Do not allow make-shift compromises to endanger property and personal safety. Contact the local building officials about restrictions and installation inspection in your area.

Before you start installing your stove, make sure that:

- The stove and chimney connection are placed far enough from combustible materials to meet all clearance requirements.
- The floor protection must be adequate and must be made correctly according to the requirements.

All necessary approvals are needed from the local building officials.

The data plate, which is located on the back of the stove, provides information regarding safety testing information, name of certified testing laboratory, and installation requirements.

Installation requirements vary in different districts, and the local building officials have the final authorization to approve your installation. You should discuss the installation with them before beginning. Please ask your dealer for further information.

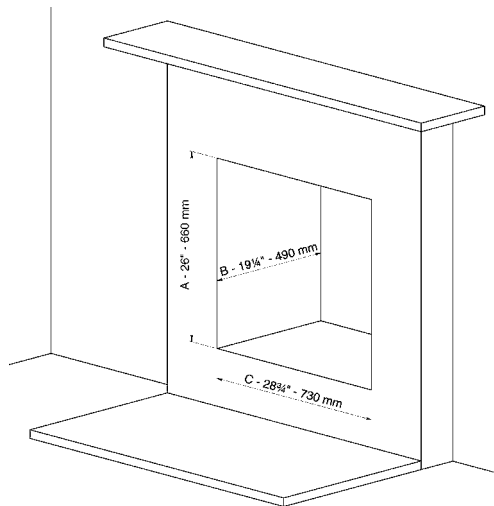

The figure above shows the required fireplace dimension required for the Morsø 5660 Standard insert.

It is easier to make adjustments to the masonry surrounding the insert, when the heavy cast iron is not connected to the steel box. Use the steel box as a template for the masonry adjustments. Allow extra room for installation, especially above the insert.

Air flow within the insert may not be altered. Follow installation instructions for optimum air flow to the firebox. Sufficient air supply is important for safe and good combustion.

Minimum masonry fireplace size

	Height (A)	Depth (B)	Width (C)
Inches/mm	26" / 660 mm	19 $\frac{1}{4}$ " / 490 mm	28 $\frac{3}{4}$ " / 730 mm

The stainless steel connector must be at least 8 feet in length.
The chimney must have a clay liner or a stainless steel liner.
Do not move bricks or mortar from the existing fireplace.
Remove or lock existing fireplace dampers in the open position.

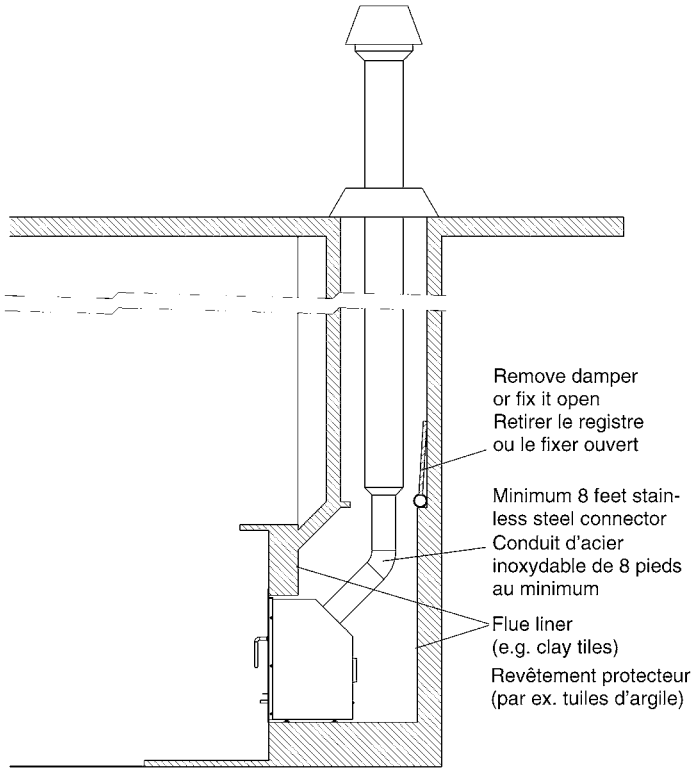

The stainless steel chimney liner (flexible or rigid) is available from most specialty stove retailers. The installation may be used with a factory built or masonry fireplace. Be sure to fulfill all requirements.

Your Morsø 5660 NA Fireplace Insert is fully assembled when you receive it. This ensures optimum protection during transportation.

However, in order to connect the stove to your chimney installation, it is necessary to dismantle the stove's flue collar. This may only be done by removing the baffle plate from the combustion chamber.

The Morsø 5660 weighs 327lbs therefore, in order to avoid damage when unpacking and installing the stove, it is recommended that two people carry out the task. Additionally, it is advisable to use an underlay (cardboard, rug, or the like) for placing parts during the installation.



The easiest way to install your 5660 NA Fireplace Insert is to follow these steps:

1. Separate the combustion chamber from the outer convection box. Dismantle and remove the internal parts of the combustion chamber. This will simplify the connection method from the flue liner to the insert.
2. Position the convection box into the fireplace opening making sure it sits level.
3. Refit and mount the combustion chamber into the convection box.
4. From inside the combustion chamber connect the chimney liner to the flue collar.
5. Re-assembly the interior parts

The installation should be done making it possible to remove the insert later on, if necessary, without damaging the masonry or other materials around the insert.



Stove door

Firstly, dismount the stove door. This will ease the installation and avoid damage. Remove the spilt pin on each hinge pin and lift up the two hinge pins, and dismount the door. Note: The brass washer in the upper hinge is loose and must be put in place again when remounting the door.

Firebox liners

Now take out the fireproof liners and insulation materials from the combustion chamber in the following sequence: Bottom liners, the two side liners, and the rear wall liner. Finally, remove the liner and the insulation mat that sit above the baffle plate in the roof of the combustion chamber.

CAUTION: The liners are very porous and must be handled with great care.



Baffle plate/secondary air supply

The baffle plate is mounted with four M8 bolts. The baffle plate is heavy (30lbs.) therefore, it is difficult to hold it in place over the four threaded holes. For this reason, two guide bolts without heads are included to facilitate the positioning.

1. The outermost bolts in each side should be removed.
2. The two guide bolts are now screwed into each of the outermost holes so that the heads are barely visible (this is necessary for the final removal of the baffle plate).
3. Next, remove the two center bolts. The baffle plate is now resting only on the two guide bolts.
4. Carefully slide the baffle plate off the guide bolts and remove from the combustion chamber.



Flue collar

The flue collar with the stop bar is unscrewed from the stove. The loose flue collar should now be connected to the flue pipe (or 8 feet stainless steel connector) or the flexible chimney liner inside chimney/fireplace opening.



Next disconnect and remove the outer trim.



Loosen the two bolts that fix the combustion chamber to the convection box. Pull out the combustion chamber from convection box. **DO NOT** lift the combustion chamber via the blower housing door.



Combustion chamber

1. Position and level the convection box into the fireplace opening. Leveling bolts are located on the base of the convection box inside the blower housing.
2. Replace and mount the combustion chamber into the convection box.
3. Connect the chimney liner to the flue collar from inside the combustion chamber. Guide the flue collar with flue pipe or liner attached through the circular hole in the back of the convection box. The flue collar (with chimney liner connected) is fastened back onto the combustion chamber. A fireplace may be constructed in several ways therefore, if necessary, ask your chimney sweep about the optimum connection method between the insert and the chimney.
4. Replace the interior parts in the reverse order when removed. The baffle plate is mounted back over the two guide bolts. Next, the two M8 center bolts are screwed in place. The two guide bolts are removed and the last two M8 bolts inserted and screwed in. Firebox liners and fireproof materials are put back in the following order: the rear liner, the two side liners, and the two bottom liners. The fireproof insulation mat is carefully put in place on top of the baffle plate. Finally, the last liner is put back in place (in front, centered on the baffle plate and slanted up towards the smoke exit hole). Caution: The liners are very porous and must be handled with great care. The stove door is repositioned on the hinges with the hinge pins. Remember to put the spilt pins and the brass washer back in place on the upper hinge. If the insert ever have to be removed for the purposes of inspecting the fireplace insert and fireplace it can be done by using the instruction for the installation (page 6-8) in the reverse order of which it was installed.



Metal Tag

Where a masonry fireplace has been altered to accommodate the 5660 Fireplace Insert, a metal data tag (enclosed) should be attached to the masonry fireplace using screws or nails. The tag should be easily visible should future homeowners wish to remove the 5660 Fireplace Insert at a later date.

1.1 The chimney / flue system

Note that the flue system must be independently secured and must not rely on the stove for support.

DO NOT CONNECT THIS UNIT TO A CHIMNEY FLUE SERVING ANOTHER APPLIANCE. (Several flues may run up a single chimney stack; use one flueway per appliance).

Use a residential type masonry or listed type HT factory-built chimney.

High Temperature (H.T.) Chimney Standard UL-103-1985 (2100° F.) for the USA, and High Temperature (650°C) Standard ULC S-629 for Canada.

This fireplace insert must be installed with a continuous chimney liner 6" diameter extending from the fireplace insert to the top of the chimney. The chimney liner must conform to the class 3 requirements of CAN/ULC-S635, Standard for Lining System for Existing Masonry or Factory-Built Chimneys and Vents, or CAN/ULC-S640, Standard for Lining Systems for New Masonry Chimneys.

The internal dimensions of the chimney connector and chimney must not be less than 6 inches diameter (or equivalent cross section), and should not be significantly larger than this. Too large a section will tend to allow the flue gases to cool excessively, causing sluggishness or unpredictability in the stove's performance.

We recommend the length of the chimney system should be at least 16 feet (not required) above the stove in normal domestic situations, measured from the flue collar to the top of the chimney.

Local conditions like for example - roof constructions, large trees nearby and high altitude, may influence the chimney draft and height. Therefore, contact the local professional chimney sweep or your Morsø dealer.

A factory-built chimney should consist of:

- Connector, rigid or flexible (between flue collar of insert and flue liner)
- Insulated High Temperature Flueliner (16 feet)
- High Temperature prefabricated Chimney Cap

Do not connect to any air distribution duct or system.

Important: If the installation instructions are not followed carefully, it may cause dangerous situations like chimney - and house fires. Follow the instructions carefully and do not deviate from them as it may cause injuries to people or property.

1.2 Flue Connection

The stove is supplied from the factory with a flue collar fitted to the top plate.

The flue collar is from the factory prepared for fitting the enclosed 6 inch adapter. Use a 24 MSG black or blue chimney connector or listed double wall chimney connector. Refer to local codes and the chimney manufacturer's instructions for precautions required for passing a chimney through a combustible wall or ceiling. Remember to secure the chimney connector with a minimum of three screws to the product and to each adjoining section. Position the stove and connect to the flue system.

Wear gloves and protective eyewear when drilling, cutting or joining sections of chimney connector.

1.3 Connection to the existing chimney

A Chimney connector is the double-wall or single-wall pipe that connects the stove to the chimney. The chimney itself is the masonry or prefabricated structure that encloses the flue. Chimney connectors are used only to connect the stove to the chimney.

Double-wall connectors must be tested and listed for use with solid-fuel burning appliances. Single-wall connectors should be made of 24 gauge or heavier gauge steel. Do not use galvanized connector; it cannot withstand the high-temperatures that smoke and exhaust gases can reach, and may release toxic fumes under high heat. The connector must be 6 inches (150mm) in diameter.

If possible, do not pass the chimney connector through a combustible wall or ceiling. If passage through a combustible wall is unavoidable, refer to the sections on Wall Pass-Throughs. Do not pass the connector through an attic, a closet or similar concealed space when installing the chimney connectors.

It is important to keep the flue gases moving smoothly in the right direction. Do not vent into a large void at this location; rather form one continuous section all the way up. Use mild bends (e.g. 45° vs. 90°) rather than sharp angles where a change of direction is required. All parts of the venting must be accessible for cleaning purposes.

Be sure the installed stove and chimney connector are correct distances from near by combustible materials. See the clearance paragraph page 12.

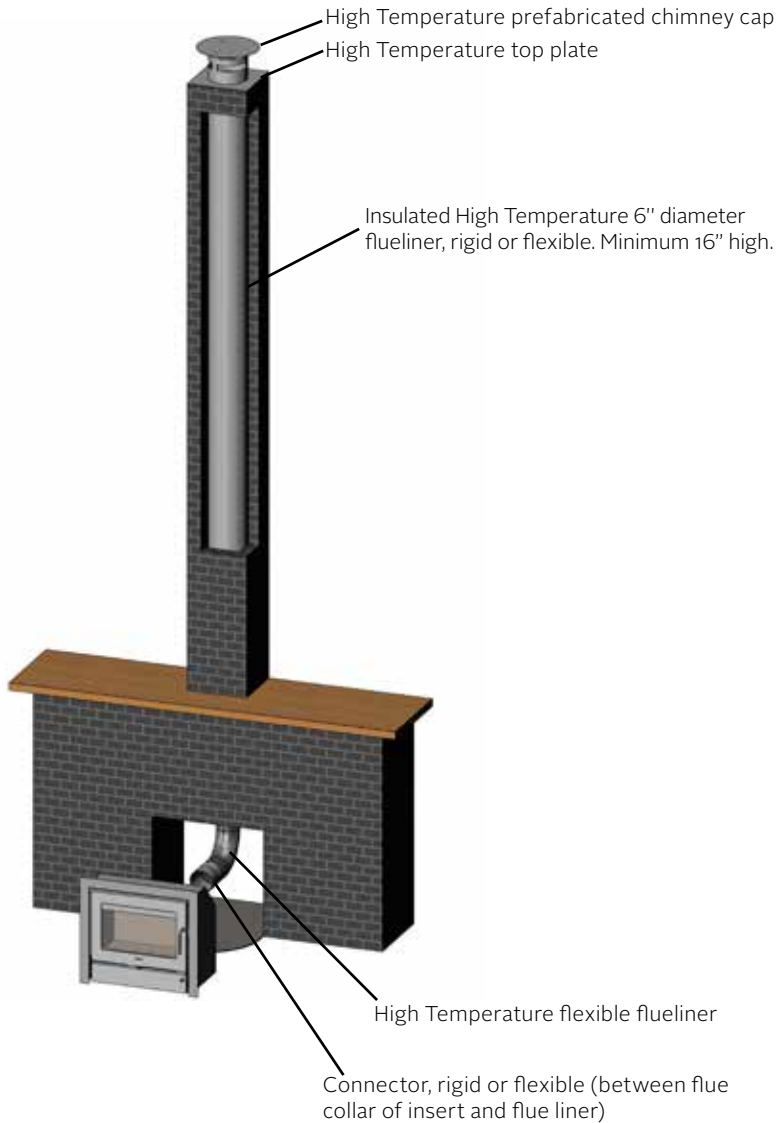

Sample installation into existing chimney.
Chimney liner system has to be UL listed to UL 1777 in USA and ULC S635 in Canada.

Chimney Connector Systems and Clearances from Combustible Walls for Residential Heating Appliances

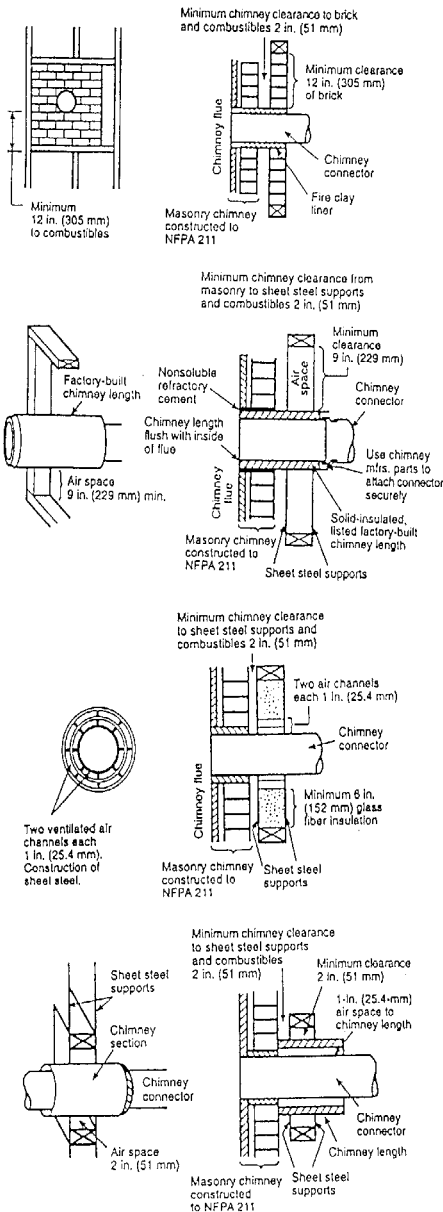

A Minimum 3.5-in thick brick masonry all framed into combustible wall with a minimum of 12-in brick separation from clay liner to combustibles. The fireclay liner shall run from outer surface of brick wall to, but not beyond, the inner surface of chimney flue liner and shall be firmly cemented in place.

B Solid-insulated, listed factory-built chimney length of the same inside diameter as the chimney connector and having 1-in. or more of insulation with a minimum 9-in. air space between the outer wall of the chimney length and combustibles.

C Sheet steel chimney connector, minimum 24 gauge in thickness, with a ventilated thimble, minimum 24 gauge in thickness, having two 1-in. air channels, separated from combustibles by a minimum of 6-in. of glass fiber insulation. Opening shall be covered, and thimble supported with a sheet steel support, minimum 24 gauge in thickness.

D Solid insulated, listed factory-built chimney length with an inside diameter 2-in. larger than the chimney connector and having 1-in. or more of insulation, serving as a pass-through for a single wall sheet steel chimney connector of minimum 24 gauge thickness, with a minimum 2-in. air space between the outer wall of chimney section and combustibles. Minimum length of chimney section shall be 12-in. chimney section spaced 1-in. away from connector using sheet steel support plates on both ends of chimney section. Opening shall be covered, and chimney section supported on both sides with sheet steel supports securely fastened to wall surfaces of minimum 24 gauge thickness. Fasteners used to secure chimney section shall not penetrate chimney flue liner.

1.4 Positioning the stove

CLEARANCE REQUIREMENTS TO COMBUSTIBLE SURFACES

The Morsø 5660 NA is approved in the US and Canada for installation into the following:

1. A masonry fireplace.
2. Morsø Fireplace Insert Zero Clearance Enclosure (separate installations instructions apply).

A	Sidewall to insert
B	Combustible mantel to insert
C	Side facing
D	Hearth extension
E	Top facing

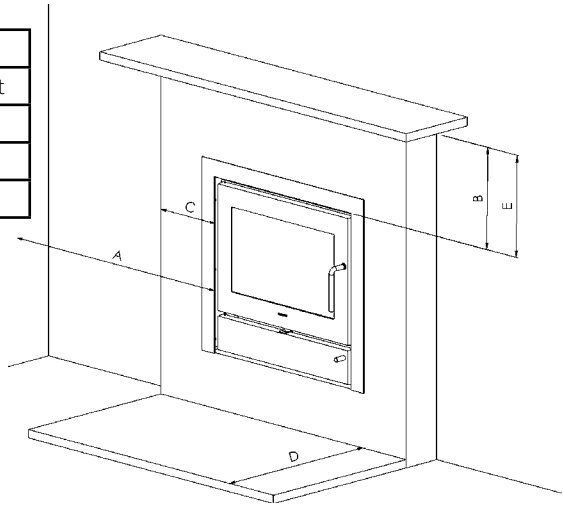

INSTALLATION	A	B	C	D	E
UNITED STATES	17"	26½"	8"	See text	26½"
CANADA	432 mm	724 mm	200 mm	below*	724 mm

When the appliance is elevated 6" (152 mm in Canada) or more above a combustible floor (as measured from the floor to the bottom of the door glass), the floor in front of the fireplace requires thermal protection equal to R-value = 1.79 ft² °F h / BTU. Floor protection must extend out minimum 21" (535 mm in Canada) and 8" (200mm in Canada) to each side of the fuel loading door

When the appliance is elevated 20.25" (515mm in Canada) or more above a combustible floor (as measured from the floor to the bottom of the door glass), the floor in front of the fireplace requires non-combustible ember protection. Floor protection must extend out minimum of 16" (450 mm in Canada) and 8" (200 mm in Canada) to each side of the fuel loading door.

The hearth requirements are summed up in the following table.

Floor protection requirements		
Distance from floor to the bottom of the door glass	Greater than 6" (152 mm)	Greater than 20.25" (515 mm)
Hearth extension in front of fuel loading door	21" (535 mm)	16" (US) 450 mm (Canada)
Hearth extension to the side of fuel loading door	8" (US) 200 mm (Canada)	8" (US) 200 mm (Canada)
Hearth material or R-value for hearth material	1.79 ft ² °F h/BTU	Non-combustible material

All floor protection materials must be non-combustible material.

FLOOR PROTECTECTOR MUST BE LISTED TO UL 1618

How to convert the specification to R-value for a given material:

- A. If the R-value (Thermal resistance) is given, no conversion is needed
- B. If the k-value (Thermal conductivity) is given with a required thickness (T) in Inches:
 $R = 1/k \times T$
- C. If the C-value (Thermal conductance) is given:
 $R = 1/C$

Do NOT install in a mobile home

Distance to furniture

The recommended minimum distance from stove to furniture is 42 inches. Note that some furniture is more easily affected by heat and may need to be moved to a greater distance. This is your responsibility.

In addition other combustible materials, away from the stove. In general, a distance of 42 inches must be maintained between the stove and moveable combustible item such as drying clothes, newspapers, firewood etc. Failure to meet the required clearances can endanger property and personal safety.

Note:

Acid Protection

If acid-washing the masonry around the stove, protect the stove surface with an acid-proof cover.

Fresh Air Inlet

Unless there is deemed to be insufficient residual air into the room via doorways, windows and the like, a dedicated fresh air inlet will be needed. This inlet should have 2 square inches (1250 square mm) of free air space. This is particularly important where the room is well sealed, or where an extractor hood or ventilation system disturbs the natural air pressure. Such an inlet should not be on a wall that is usually subject to negative pressure from normal wind pattern. Avoid placing the inlet directly across the room from the stove, thus causing a cold air draft.

1.5 Installing the Optional Blower Kit

Blower kit contents:

- Thermostat-controlled blower unit
- Speed controller
- Cable ties to fix cord
- Magnetic thermostat sensor

The installation of the blower unit can easily be achieved without the need to remove the insert.

Installing the blower unit (fig A):

The blower unit sits inside the blower housing at the base of the convection box situated behind the front access door under the main firebox.

The blower unit (1) should be placed on the base of the convection chamber and to the rear. It should be centered between the two rectangular ventilation holes (2) in the base.

A series of magnets (6) attached to the base and rear wall of the blower unit are used to secure the blower unit to the base and back wall of the convection chamber. The mouth of the fan unit **MUST** face upwards.

Attaching the Thermostat Sensor

The thermostat sensor is a heat activated device that allows the blower to operate when the stove reaches the required running temperature. The thermostat sensor magnetically attaches to the heat shield positioned at the roof of the blower housing (i.e. the underside of the firebox).

Securing the Power Cord

The power cord can exit the blower chamber either from the left or the right side through cut-outs (7) provided in the side walls of the convection box. The power cord should be secured in place using the cable ties (4) supplied. Additional securing points (8) are provided to the front left and right sides of the blower housing door and should be utilized as a final fixed point for the cord prior to final exit.

Attaching the Speed Controller:

The speed controller is attached across the ventilation grill at the front right of the blower housing base using two hex-head bolts supplied.

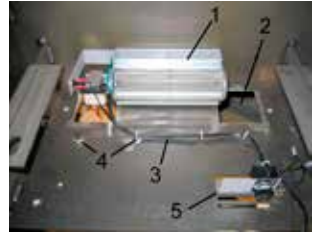
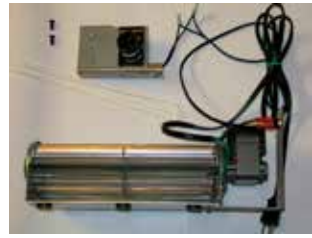

2.0 Operation

2.1 Before you start firing

For use with solid wood fuel only. Use of inappropriate fuel can result in the release of toxic fumes.

Do not overfire, if heater or chimney connector glows you are overfiring.

Inspect and clean chimney frequently. Under certain conditions of creosote buildup may occur.

To reduce the risk of smoke and flame spillage, operate only with door fully closed.

Hot while in operation. Keep children, clothing and furniture away. Contact may cause skin burns.

CAUTION

Never use gasoline, gasoline-type lantern fuel, kerosene, charcoal lighter fluid or similar liquids to start or 'freshen up' a fire in this heater. Keep all such liquids away from the heater while it is in use.

Choosing your fuel

All types of natural wood can be burned on your stove, but they must be well-seasoned and dry. Once the wood is cut to length, it should be split down middle - to suit the dimensions given below - to allow moisture to evaporate.

Cut the wood to a length of max 21 inches (53 cm) and approx. 3 to 3,5 inches (7-8 cm) in section. If you can weigh your wood, aim for around 2 lbs. For correct combustion and heat output, wood fuel should contain no more than 20% moisture; this can easily be checked by using the Morsø Moisture Meter (part # 62929900).

To naturally season wood fuel, stack and store it under cover in an airy location where fresh air can move through each piece. Some soft woods may take as little as one good summer to season whereas harder woods such as oak, maple, and elm may require seasoning up to 18 months. Avoid overly dry wood that is gray in color as under certain conditions it can cause performance problems, such as back-puffing and sluggishness. Well seasoned wood will be light to hold and will show signs of cracking from the center-out in the ends. If your wood spits or sizzles when burnt, and your stove's door glass persistently mists up, your wood is not properly seasoned. Never use drift wood (from the sea), whose salt content may cause corrosion, nor construction wood that may have been impregnated with chemicals.

Starting the first fire

The initial fire should be small, so that the stove paint can cure and the main plates of the stove can settle into position. Some fumes will be given off by the paint. Ventilate the room during this phase.

The setting of the air control lever, lighting techniques and loading intervals will depend on chimney draft, the fuel used, the heat required and so on. Some basic techniques are outlined below.

In principle

Your stove has three air supplies:

Primary air is controlled by the air controller beneath the door. The air from here passes through internal channels and eventually washes at high speed down the back face of the door glass. This super-heated air helps with the combustion of volatile gases produced by the fire.

Secondary air is supplied to the top of the fire through holes in the tubes under the lower baffle. This effectively burns off other residual gases, making for very clean emissions. This air supply is constant and cannot be varied.

Pilot air is supplied to the firebed through a hole placed behind the front grate. This air will activate the embers. This air supply is factory set and cannot be varied.

2.2 Lighting and loading intervals

When first lighting the stove, a large volume of air is needed. When the stove is cold, you should leave the door open an inch or two for the first few minutes and open the primary air supply completely. While the door is open, do not leave the stove unattended.

To establish a reasonable bed of ash on the firebox floor, you should use 5-6 inches thickness (4-6 pound) of dry kindling at the initial lighting. Always maintain a 1-1,5 inch (2-3 cm) layer of ash on the floor of the combustion chamber at all other times.

1. A layer of embers will form rapidly if the stove is lit with fire lighters or 7-10 rolled up sheets of newspaper, underneath roughly 4-5 lb. of dry kindling.



2. Light the fire.



3. Fully open the air controller so that primary air can enter the firebox.

4. After the paper/fire lighters have caught fire, leave the fire door ajar about 1 inch, so that the chimney draws well.

5. After 5-10 minutes the chimney draft should be established, at this point close the fire door. If all the necessary conditions are met, a nice layer of embers will start to accumulate after another 15-20 minutes.



6. Refuelling of your stove should be done while there are still glowing embers in the bed. Spread the embers across the bottom, but concentrated mostly towards the front of the stove.



7. Place 2-3 pieces of fuel weighing roughly 4-6 lb. across the embers in one layer, with spacing of roughly 1 inch between the pieces of wood.

8. When the primary air supply is open all the way and the door is closed, the new fuel will ignite in a few minutes.



9. Once the new fuel has taken, adjust the primary air amount to the desired setting; optimal combustion will continue until glowing embers are produced.

10. A new charge of wood can be added by repeating steps 6 & 7.



Do not support the fuel with use of grates, andirons or other methods.

CAUTION

Never allow the fire to rest directly on the glass. The logs should always be spaced at least one inch from the glass to allow for proper air flow within the stove.

Do not for any reason attempt to increase the firing of your heater by altering the air control adjustment range outlined in these directions.

Warning: Fireplace stoves must never be left unattended with doors open.

If the door is left partly open, gas and flame may be drawn out of the fireplace stove opening, creating risks from both fire and smoke. We recommend you to fit a smoke detector in the room where the stove is installed.

DO NOT OVERFIRE THIS HEATER. Overfiring may cause a house fire, or can result in permanent damage to the stove. If any part of the stove glows, you are overfiring.

The maximum recommended weight of wood fuel per load is 2.5 kg/h/5.5lbs (approx 3 split logs).

Draft conditions

If smoke or fumes come out of your stove when lighting up and reloading, or if the fire simply will not respond, a poor draft is almost certainly to blame. (In a very few cases, there may be insufficient fresh air getting into the room - see installation advice above). Take advice from your stove supplier on how best to upgrade your flue system to improve draft.

Rules of woodburning

If you want less heat, put fewer logs on the stove and reduce the amount of air. It is still important to maintain a good layer of embers.

Less heat - less wood - less air

Greater heat - more wood - more air

Soot deposits will settle on the glass if the stove is run too slowly or if your wood is not well seasoned.

3.0 Maintenance

When performing maintenance on your stove, always protect yourself, using safety goggles and gloves.

3.1 Exterior Maintenance

The stove surface is painted with heat-resistant Senotherm paint. It is best kept clean by vacuuming with a soft brush attachment or by wiping with a lint-free cloth.

Over a period of time, the painted surface may become slightly grey. A can of Morsø touch-up spray paint should be available from your stove supplier. This can be applied - in accordance with the instructions - in just a few minutes. When first firing after touching up, the stove will give off a slight smell as the paint cures. Make sure to ventilate the room well during this phase.

3.2 Internal maintenance

Glass

If the stove is generally run at the correct temperatures, there should be little or no dirt on the glass. If dirt does settle during lighting, most will burn off as temperatures increase. For heavier deposits that will not burn off, use Morsø glass cleaner, applied when the glass is cold, in accordance with the instructions. Never clean the glass when it is hot. Never use abrasive cleaners on the glass surface.

Reasons for dirty glass

- Fuel too wet
- Logs too large or not split
- Combustion temperatures too low

Replace broken glass immediately.

Do not operate your stove if the glass in the door is damaged.

WARNING

If you need to replace the glass, replace it with high temperature ceramic glass (part #79560100) supplied by Morsø, contact your Morsø dealer. Do not use substitutes.

Installing the glass

Never install the glass when the stove is in function.

Ceramic glass replacement

Ceramic glass cannot be recycled because it has a higher melting point than ordinary glass. If ceramic glass is mixed with ordinary glass, the raw material is spoiled, and the reclaiming process may be halted. Take care that the ovenproof glass does not end up among ordinary recycled waste. That will be a great benefit to the environment. Note: Should be handed in to a recycling station as ceramic glass.

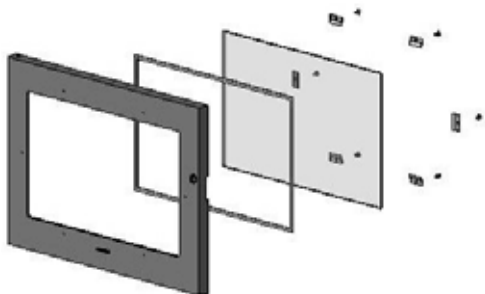

1. Detatch the door (See page 6) off its hinges an place face-down on a sheet of cardboards or other nonabrasive fabric.
2. Unscrew the six bolts that secure the glass. (In the event that a bolt sheers off when being unscrewed, remove the remaining body of the bolt by drilling down its center with 1/8 inch high speed steel drill bit. Smaller drill bits may be successful, but do not use a larger bit. Make sure the bit stays away from the edges of the bolt - this may damage the thread in the cast iron.
3. Remove the old ceramic gaskets and clean up the surface underneath with wire wool or emery paper to remove loose particles.
4. Place the new gasket material in position around the perimeter of the window area, making sure to pinch them to the length in such a way that they make a continuous seal. Leave no gaps.
5. Place the new glass in position on the strips and screw home the fresh bolts and fitting by hand.
6. Finally, give each of the bolts an extra half turn or so. The glass should held tight enough by that cleaning will not dislodge it. Do not over-tighten the bolts as this may put excessive pressure on the glass, resulting in cracking - important!

To reduce the risk of breaking the glass, avoid striking the glass or slamming the door.

Internal service parts

The flame-path equipment - consisting of firebricks, glass, baffle, pilot air assembly and flue collar - are subject to the extremes of heat produced by the fire. From time to time, one or other of these parts may need replacing as a matter of routine maintenance. Contact your Morsø dealer for replacement parts. Do not use substitutes.

NOTE: The flame-path equipment, the ceramic rope and the paint finish are not covered by guarantee.

All of these service parts can be bought from your Morsø dealer, and we recommend that damaged parts are replaced as soon as possible to avoid collateral damage.

Should the baffle be distorted by an overfire, the stove will still function, although its efficiency may be compromised. Replace it as soon as possible. Remove the baffle, scrape out the old fire cement and replace with new to make an effective seal.

Reasons for fast internal wear and tear

Persistent heavy firing
Soot and ashes left to accumulate

Rope Gasket

The rope gasket around the perimeter of the door may harden over a period of time. It should be replaced if it becomes difficult to close the door or if air starts to leak in around the perimeter of the door, causing the fire to become a little less controllable. A Morsø rope gasket kit is available from your stove supplier.

3.3 Cleaning the Stove and the Flue

Check for soot above the baffle plate and around the flue outlet every month or so to start with. If the stove suddenly becomes sluggish, check for a soot fall around the flue collar or in the flue/chimney. Inspect every month.

Clean the flue/chimney - all the way from the stove and through the flue terminal point above the house.

A good routine is to clean the flue after each heating season in any case, and inspect prior to the season to ensure that bird's nests or other blockages have not occurred during the off season.

Disposal of Ashes – Ashes should be placed in a metal container with a tight-fitting lid. The closed container of ashes should be placed on a noncombustible floor or on the ground, well away from all combustible materials, pending final disposal. If the ashes are disposed of by burial in soil or otherwise locally dispersed, they should be retained in the closed container until all cinders have thoroughly cooled.

CAUTION

Never empty a stove whilst in operation.

Never use your household or shop vacuum cleaner to remove ash from the stove; always remove and dispose of the ash properly.

Creosote - formation and need for removal

When wood is burned slowly, it produces tar and other organic vapors, which combine with expelled moisture to form creosote. The creosote vapors condense in the relatively cool chimney flue of a slow-burning fire. As a result, creosote residue accumulates on the flue lining. When ignited this creosote makes an extremely hot fire. When burning wood, inspect the chimney connector periodically to determine if a creosote buildup has occurred.

The chimney connector and chimney should be inspected at least once every two months during the heating season to determine if a creosote buildup has occurred. IF creosote has accumulated it should be removed to reduce the risk of a chimney fire.

Chimney sweeping

Inspect the system regularly during the heating season as part of a regular maintenance schedule.

To inspect the chimney, let the stove cool completely. Then, using a mirror, sight up through the flue collar into the chimney flue. If you cannot inspect the flue system in this fashion, the stove must be disconnected to provide better viewing access.

Clean the chimney using a brush the same size and shape as the flue liner. Run the brush up and down the liner, causing any deposits to fall to the bottom of the chimney where they can be removed through the clean-out door.

Clean the chimney connector by disconnecting the sections, taking them outside, and removing any deposits with a stiff wire brush. Reinstall the connector sections after cleaning, making sure to secure the joints between individual sections with sheet metal screws.

If you cannot inspect or clean the chimney yourself, contact your local professional chimney sweep or local Morsø Deler.

If you do experience a chimney fire, act promptly and:

1. Close the air control.
2. Get everyone out of the house.
3. Call the Fire Department.

Annual maintenance

Before the heating season, perform a thorough cleaning, inspection and repair:

Thoroughly clean the chimney and chimney connector.

Inspect the chimney for damage and deterioration. Replace weak sections of prefabricated chimney. Have a mason make repairs to a masonry chimney.

Inspect the chimney connector and replace any damaged sections.

Check gasketing for wear or compression, and replace if necessary.

Check the glass for cracking; replace if needed.

Check door and handles for tightness. Adjust if needed.

3.4 Leaving the stove for extended periods

Important:

If the stove is to be left unused for any period of time, clean it out thoroughly and leave the handle for primary air inlet slightly open to allow airflow. Make sure that the flue does not allow rainwater to come anywhere near the stove; install a chimney cap, but do not block off the flue completely.

These measures should ensure there is a slight movement of air through the stove, and that the body of the stove remains dry, right into the corners.

Any ash left within an unfired stove can attract moisture like blotting paper. If moisture is allowed to settle within the stove, rust will form. Rust expands as it takes a grip. This can lead to undue pressure on the stove joints, and this in turn may result in damage to the stove.

NOTE: It is best to thoroughly clean the stove after the heating season has concluded. Adding a dessicant, such as kitty litter, into the stove bottom helps absorb moisture during the summer months. Be sure to remove this prior to the heating season.

Thank you for buying a Morsø stove.

We hope you have many years of carefree warmth in its company. Some initial experimentation with loading and running techniques will decide your normal routine. If you have any problems after this short learning phase, please refer to your stove dealer. Should they be unable to help for any reason, please contact us in writing at the address on the front of this publication.

3.5 Parts diagram for model Morsø 566o

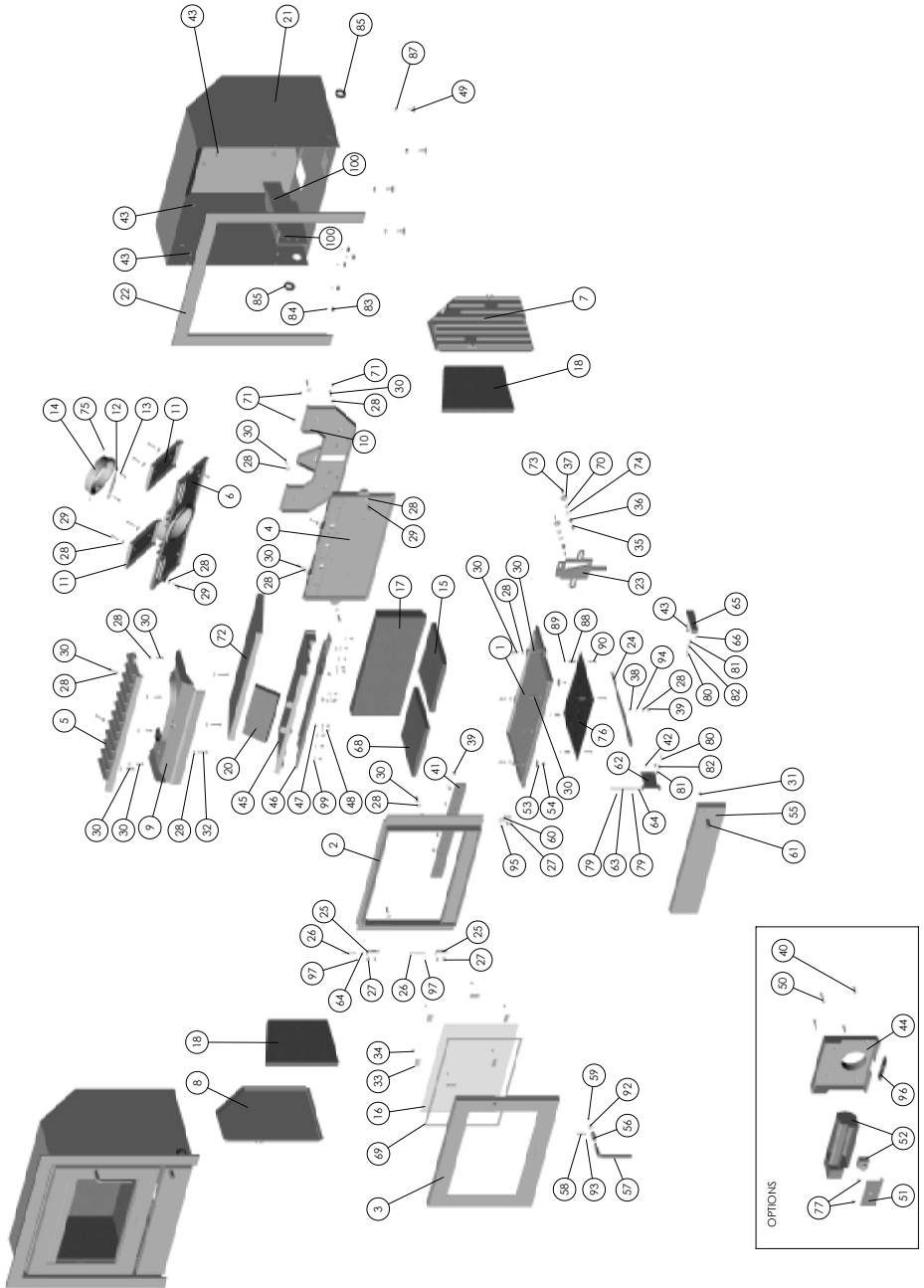

3.6 Parts list for model Morsø 5600

Pos. No.	Parts	
1	Bottom plate 5600	44560121
2	Front frame 5600	44560221
3	Door 5600	44560321
4	Rear plate 5600	44560400
5	Top plate 5600	44560521
6	Top plate Inclined 5600	44560800
7	Side plate right 5600	34560600
8	Side plate left 5600	34560700
9	Air Canal Top inside 5600	34560900
10	Air Canal Rear 5600	44561000
11	Air Canal Inclined 5600	34561100
12	Stop bar 5600	71561100
13	Screw	-
14	Flue collar	44344721
15	Stone bottom right 5600 NA	79562000
16	Glass 5600	79560100
17	Stone back 5600 NA	79561800
18	Stone side - 5600 NA	79561900
19	-	-
20	Vertical baffle plate	79560700
21	Insert box 5600 NA	71561521
22	Insert Frame 5600 NA	71561621
23	Secondary draft control	71560500
24	Handle sek. draught control	71560600
25	Door fitting	71810100
26	Hinge pin	74701000
27	Screw	738615
28	Washer	791891
29	Screw	731630
30	Screw	731625
31	Screw	73861100
32	Screw	731640
33	Glass fitting	54146361
34	Screw	73850800
35	Distance tube	71562600
36	Distance tube	71562700
37	Washer	79189500
38	Distance tube	54202500
39	Screw	73860900
40	Screw	73865500
41	Cover f. Pilot air 5600	71561000
42	Screw	73860900
43	Screw	-
44	Airtight Canal 5600	34561200
45	Baffle plate 5600	44561400
46	Baffle plate, stainless	71561300
47	Screw	73886000
48	Screw	74160804
49	Adjustment base 5600	71560700
50	Screw	73863500

3.6 Parts list for model Morsø 5660

Pos. No.	Parts	
51	Mounting plate Blower	71563100
52	Blower	54560100
53	Washer	79189800
54	Screw	73861800
55	Front cover 5600 NA	44561321
56	Axis for handle	71562061
57	Door handle, stainless steel	75263600
58	Hinge pin	541082
59	Screw	73960700
60	Closing plate	71562100
61	Knob front cover	71562200
62	Front Cover Fitting	71562300
63	Hinge pin	54502900
64	Washer	746006
65	Magnet fitting	71562400
66	Magnet	79082003
68	Stone bottom left 5600 NA	79562100
69	Adhesive fibre for door glass	79074500
70	Spring	79049100
71	Screw	731606
72	Insulation	79561300
73	Screw	743625
74	Washer	79190100
75	Screw	791835
76	Radiation Shield Base	71563000
77	Screw	-
79	Lock ring	791824
80	Screw	-
81	Cable relief, iron	76560400
82	Cable relief, plastic	76560500
83	Armature for cable relief	76560200
84	Tubular rivet	74700400
85	Nipple	76560100
86	Cable tie	76560300
87	Locking nut	745010
88	Distance tube	-
89	Washer	-
90	Screw	-
92	Spring for Handle	79048800
93	Hinge pin	74201900
94	Washer	-
95	Screw	-
96	Cover plate for air tight	73563300
97	Split pin	73530700

Guarantee Product Registration

MORSØ 10 YEAR GUARANTEE CERTIFICATE

Behind every Morsø stove is more than 160 years of dedicated stove design and manufacturing experience. Quality control has always been at the heart of the production process and detailed measures have been put into place at all key stages of the build. Accordingly, provided that the stove has been supplied by an authorised Morsø dealer, Morsø will offer a 10-Year Manufacturers Guarantee against manufacturing defect to any of the main exterior body parts of its stoves.

**Read more about "Morsø 10 years guarantee/product registration card" and
REGISTER your new Morsø stove online:
<http://international.morsoe.com/warranty-registration>**

IMPORTANT!

How to heat safely for the environment and yourself!

- **Use only dry wood**

Use only dry (max. 20% moisture content) and untreated wood. The fuel must be split and 8 - 12 cm thick.

- **Light**

Light with dry kindling (use 1 - 2 kg). Leave the door ajar and stay close to the stove during the lighting phase.

- **Good layer of embers**

Be certain to have a good layer of embers before refilling. The wood should light within 2 minutes. If the logs do not ignite it may, in an extreme case, cause the flue gases to ignite which may pose a risk to material damage or personal injury.

- **Refuelling**

When refuelling use 2 - 3 pieces of wood - no more than 2 - 2.5 kg.

- **Ensure adequate air**

i.e. clear and yellow flames.

- **Never burn overnight**



By appointment to The Royal Danish Court

morsø

Morsø Jernstøberi A/S - 01.12.2015 - 72560400

MORSØ JERNSTØBERI A/S · DK-7900 NYKØBING MORS
E-Mail: stoves@morsoe.com · Website: www.morsoe.com